

Product: Unit Handling

Equipment: Belt Driven Live Roller Conveyors - Center and End Driven

To be located on conveyors where there are exposed moving parts which must be unguarded to facilitate function, i.e. rollers, pulleys, shafts, chains, etc.

To be placed along both sides of these conveyors since these conveyors provide surfaces and profiles attractive, but hazardous, for climbing, sitting, walking, or riding.

To be placed on removable guards to warn that operation of the machinery with guards removed would expose chains, belts, gears, shafts, pulleys, couplings, etc. which create hazards

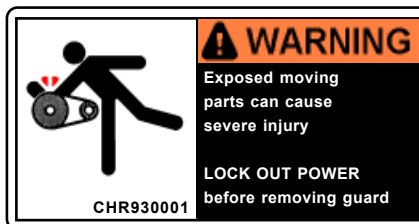
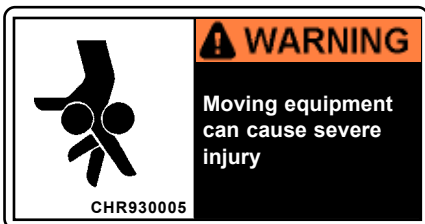

"A"
LOCATE AT TERMINAL ENDS
(BOTH SIDES)

"B"
SPACE UP TO A MAXIMUM OF 20 FT.
CENTERS (BOTH SIDES)

"C"
LOCATE ON DRIVE GUARDS
AND CHAIN / BELT GUARDS

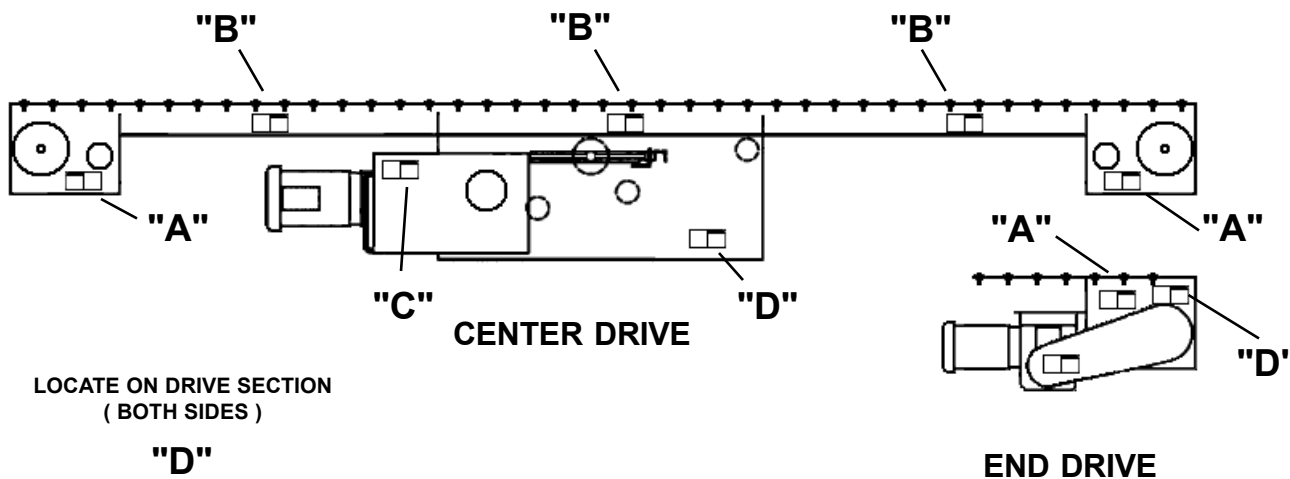

General purpose label to warn maintenance personnel that conveyors should be shut off and locked out prior to servicing; Examples: drives, take-ups, lubrication points which require guard removal.

